

# Bus Commuter Card Spec

## Commuter Card Artwork Specifications (Global Production)

<b>Display Area:</b>	See diagram below (full size)
<b>Overall Size:</b>	See diagram below (full size)
<b>Bleed:</b>	3mm all around
<b>File Format:</b>	High Res CMYK PDF. Embed/ outline images and fonts
<b>File Size:</b>	Up to 25MB
<b>File Name:</b>	SiteType_LiveDate_Campaign Name
<b>DPI:</b>	300 dpi minimum
<b>Barcoding:</b>	To be added by our printer

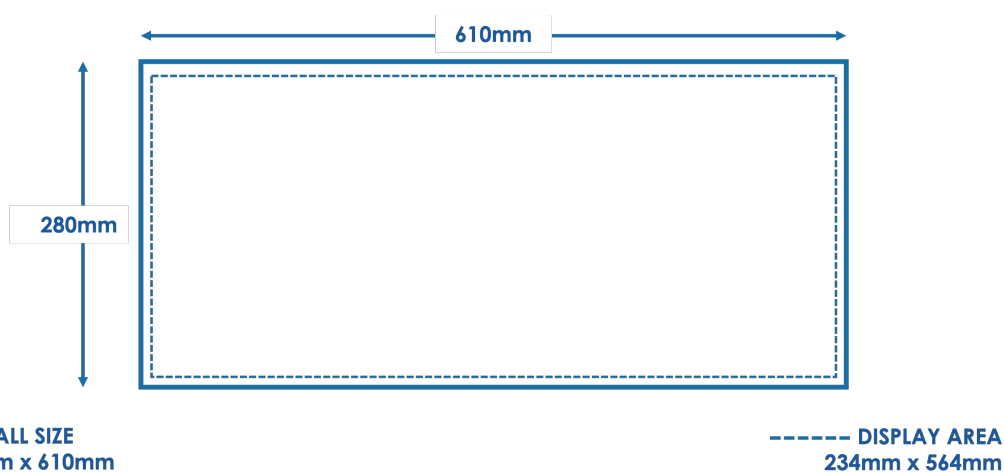

**Display Area:** For all site types that are fixed into frames, the specification will give the Overall Size and the Display Area. Please keep all important text and images within the Display Area but feel free to bleed the background colours/images up to the Overall Size. Please be aware that if an artwork has text that has been created to the Display Area it will butt-up to the frame. If this is not the desired effect, then please move the text even further inside the Display Area.

Global strongly recommends that you do not use the frame as a 'cropping device' for corporate logos and borders, as 100% accuracy cannot be guaranteed.

**Artwork Deadline:** Artworks must be with Global **28 calendar days** before the in-charge date.

**Artwork Delivery:** Please send all artwork to [productionNI@global.com](mailto:productionNI@global.com)

Files larger than 10MB may be rejected by our server and should be sent via an online file transfer service such as [wetransfer.com](http://wetransfer.com).

## Artwork and Poster Delivery

For any artwork queries, or delivery queries (if you are delivering your own posters) please contact the production team at [productionNI@global.com](mailto:productionNI@global.com) or by calling **028 4451 1888**

## Commuter Card Print Specifications (Non-Global Production)

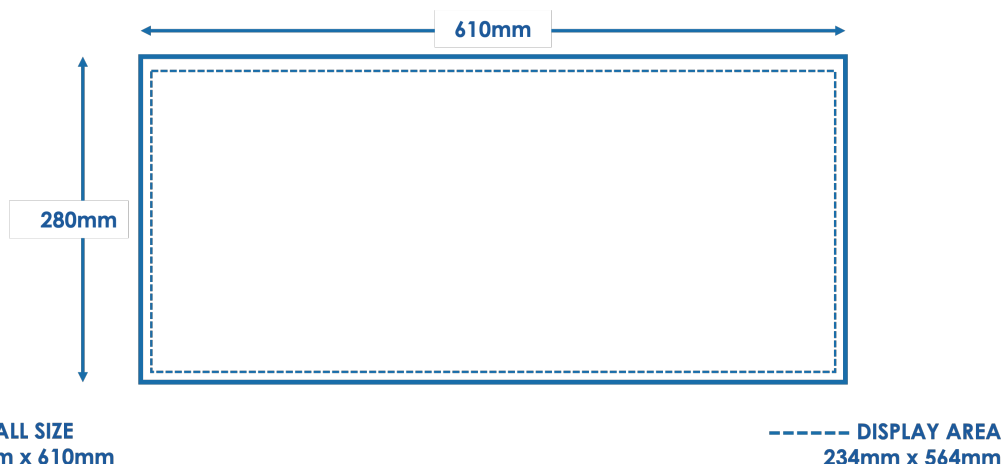

- Trim Size:** Must be trimmed to overall size – see above diagram
- Material:** Approved Vinyl only inc. GRAFITYP M112R, ORACAL 1620 or RITRAMA 04350 RI-145/100
- Finishing:** All posters must be trimmed to the exact Overall Size with additional UNPRINTED overlaps where necessary.
- Packing Details:** Posters must be delivered flat and wrapped in packages of no more than 100. Please ensure that the edges are fully protected to avoid damage in transit. Folded vinyls cannot be accepted.
- Every consignment of posters delivered must have a Delivery Note attached indicating the advertiser, the number of designs, a title for each of the designs and the quantity of each design.
- Spare Posters:** A minimum of 10% posters is recommended
- Delivery Deadline:** Posters must be produced to the exact specification set out below and delivered **14 calendar days before** the 'In-charge' date of the campaign. Please note: Global is not liable for compensation claims against any campaign where posters have been received after the delivery deadline. All posters received after the delivery deadline will not be posted until the next available posting cycle for this site type.
- Poster Delivery:** Posters should be delivered to: Global Service Depot, Unit F9, Inspire Business Park, Carrowreagh Road, Dundonald BT16 1QT.
- Barcodes:** Every bus campaign must have the appropriate barcode printed on all posters. The barcode for each campaign can be provided at any time but will be issued automatically at the time of booking with the Confirmation of Order. Even though these are a smaller site type that are viewed at close quarters they still require a barcode. To lessen the impact of the barcode you can print it at half the normal depth but do not alter the width. See the examples below.



### Artwork and Poster Delivery

For any artwork queries, or delivery queries (if you are delivering your own posters) please contact the production team at [productionNI@global.com](mailto:productionNI@global.com) or by calling **028 4451 1888**

# Artwork Approval and Compliance

All artworks must adhere to guidelines set out by our franchise partners, as well as those of the Advertising Standards Authority (ASA) in line with the United Kingdom Code of Non-Broadcast Advertising, Sales Promotion and Direct Marketing.

Global reserves the right to refuse a poster design or creative without providing specific reasons.

We actively encourage our clients, agencies, and specialists to send us artwork in advance of production to avoid any costly re-prints.

Advertisements will not be accepted for, or retained on display in the sites managed by Global if in the opinion of Global they:

1. do not comply with the law or incite anyone to break the law
2. do not comply with the Advertising Standards Authority (ASA) guidance or the UK Code of Non-Broadcast Advertising, Sales Promotion and Direct Marketing (CAP Code) which includes regulations regarding advertising, sales promotion, and direct marketing
3. do not promote equality of opportunity for all persons irrespective of their race, sex, disability, age, sexual orientation, or religion
4. are likely to offend the general travelling public or depict or offend ethnic, religious, or other major groups on account of the nature of the product or service being advertised, the wording or design of the advertisement or inference contained therein
5. are likely to be defaced
6. depict men, women, or children in a sexual manner, or display nude or semi-nude figures in an overtly sexual context. For example, whilst the use of undressed people in most underwear advertising may be seen as an appropriate context, gratuitous use of an overtly sexual nature will be viewed as unacceptable
7. depict or refer to indecency or obscenity, depict bodily functions or use obscene or distasteful language
8. advertise lap-dancing, gentlemen's clubs, escort agencies, or massage parlours
9. depict direct and immediate violence to anyone shown in the poster or to anyone looking at the poster
10. condone or provoke anti-social behaviour
11. advertise films which have not been granted permission for public exhibition or which do not show the required certificate except when the name of the cinema is not shown. Films carrying an 18 certificate must also carry the Advertising Viewing (AVC) logo
12. contain images or messages that relate to matters of public controversy and sensitivity
13. are of a political nature calling for the support of a particular viewpoint, policy or action or attacking a member or policies of any legislative, central, or local government authority (advertisements are acceptable which simply announce the time, date, and place of social activities or of a meeting with the names of the speakers and the subjects to be discussed)
14. contain illustrations which depict, or might reasonably be assumed to depict, quotations from or references to a living person unless the written consent of that person is obtained and is produced to Global. Global will require an indemnity against any action by that person or on that person's behalf before such illustrations, quotations or references will be accepted
15. use handwriting or illustrations that would suggest the poster has been damaged, defaced, fly posted or subjected to graffiti, after it has been posted.
16. might adversely affect in any way the interest of the site owner e.g. Translink

To avoid last minute difficulties and the possibility of wasted production costs, Global is happy to advise on the likelihood of a poster's acceptability prior to the copy deadline.

It remains the advertiser's responsibility to ensure creative or advertisement copy does not breach copyright or other intellectual property rights. Licensed brand images and logos require the express permission of the owner before use. Global is not responsible for property rights or permissions.

## Artwork and Poster Delivery

For any artwork queries, or delivery queries (if you are delivering your own posters) please contact the production team at [productionNI@global.com](mailto:productionNI@global.com) or by calling **028 4451 1888**